

# TSD80R1K3S1/TSU80R1K3S1

## 800V 4.4A N-Channel SJ-MOSFET

### General Description

Truesemi SJ-FET is new generation of high voltage MOSFET family that is utilizing an advanced charge balance mechanism for outstanding low on-resistance and lower gate charge performance. This advanced technology has been tailored to minimize conduction loss, provide superior switching performance, and withstand extreme dv/dt rate and higher avalanche energy. SJ-FET is suitable for various AC/DC power conversion in switching mode operation for higher efficiency.

### Features

- 850V @T<sub>J</sub> = 150 °C
- Typ. R<sub>DS(on)</sub> = 1.1Ω
- Ultra Low gate charge (typ. Q<sub>g</sub> = 6nC)
- 100% avalanche tested

TSD80R1K3S1  
Top View Bottom View

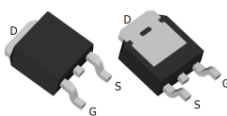

TO-252

TSU80R1K3S1

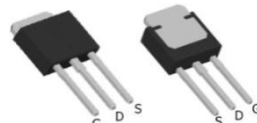

TO-251

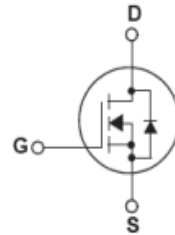

### Absolute Maximum Ratings

Symbol	Parameter	Value	Unit
V <sub>DSS</sub>	Drain-Source Voltage	800	V
I <sub>D</sub>	Drain Current -Continuous (TC = 25°C) -Continuous (TC = 100°C)	4.4* 2.8*	A
I <sub>DM</sub>	Drain Current – Pulsed (Note 1)	12*	A
V <sub>GSS</sub>	Gate-Source voltage	±30	V
E <sub>AS</sub>	Single Pulsed Avalanche Energy (Note 2)	46	mJ
I <sub>AR</sub>	Avalanche Current (Note 1)	1	A
E <sub>AR</sub>	Repetitive Avalanche Energy (Note 1)	0.2	mJ
dv/dt	Peak Diode Recovery dv/dt (Note 3)	15	V/ns
P <sub>D</sub>	Power Dissipation (TC = 25°C)	37	W
T <sub>J</sub> , T <sub>STG</sub>	Operating and Storage Temperature Range	-55 to +150	°C
T <sub>L</sub>	Maximum Lead Temperature for Soldering Purpose, 1/8" from Case for 5 Seconds	300	°C

\* Drain current limited by maximum junction temperature.

### Thermal Characteristics

Symbol	Parameter	Value	Unit
R <sub>θJC</sub>	Thermal Resistance, Junction-to-Case	3.41	°C/W
R <sub>θCS</sub>	Thermal Resistance, Case-to-Sink Typ.	0.5	°C/W
R <sub>θJA</sub>	Thermal Resistance, Junction-to-Ambient	62	°C/W

## Electrical Characteristics TC = 25 °C unless otherwise noted

Symbol	Parameter	Conditions	Min	Typ	Max	Unit
Off Characteristics						
BV <sub>DSS</sub>	Drain-Source Breakdown Voltage	V <sub>GS</sub> = 0V, I <sub>D</sub> = 250μA, T <sub>J</sub> = 25 °C	800	--	--	V
		V <sub>GS</sub> = 0V, I <sub>D</sub> = 250μA, T <sub>J</sub> = 150 °C	--	850	--	V
ΔBV <sub>DSS</sub> / ΔT <sub>J</sub>	Breakdown Voltage Temperature Coefficient	I <sub>D</sub> = 250μA, Referenced to 25 °C	--	0.6	--	V/°C
I <sub>DSS</sub>	Zero Gate Voltage Drain Current	V <sub>DS</sub> = 800V, V <sub>GS</sub> = 0V -T <sub>C</sub> = 150 °C	--	-- 10	1 --	μA μA
I <sub>GSSF</sub>	Gate-Body Leakage Current, Forward	V <sub>GS</sub> = 30V, V <sub>DS</sub> = 0V	--	--	100	nA
I <sub>GSSR</sub>	Gate-Body Leakage Current, Reverse	V <sub>GS</sub> = -30V, V <sub>DS</sub> = 0V	--	--	-100	nA
On Characteristics						
V <sub>GS(th)</sub>	Gate Threshold Voltage	V <sub>DS</sub> = V <sub>GS</sub> , I <sub>D</sub> = 250μA	2.5	--	4.5	V
R <sub>DS(on)</sub>	Static Drain-Source On-Resistance	V <sub>GS</sub> = 10V, I <sub>D</sub> = 2A	--	1.1	1.3	Ω
g <sub>FS</sub>	Forward Trans conductance	V <sub>DS</sub> = 40V, I <sub>D</sub> = 4A (Note 4)	--	4	--	S
R <sub>g</sub>	Gate resistance	f=1MHz, open drain	--	3.5	--	Ω
Dynamic Characteristics						
C <sub>iss</sub>	Input Capacitance	V <sub>DS</sub> = 25V, V <sub>GS</sub> = 0V, f = 1.0MHz	--	290	--	pF
C <sub>oss</sub>	Output Capacitance		--	90	--	pF
C <sub>riss</sub>	Reverse Transfer Capacitance		--	7.5	--	pF
Switching Characteristics						
t <sub>d(on)</sub>	Turn-On Delay Time	V <sub>DD</sub> = 400V, I <sub>D</sub> = 2A R <sub>G</sub> = 20Ω (Note 4, 5)	--	19	--	ns
t <sub>r</sub>	Turn-On Rise Time		--	19	--	ns
t <sub>d(off)</sub>	Turn-Off Delay Time		--	36	--	ns
t <sub>f</sub>	Turn-Off Fall Time		--	21	--	ns
Q <sub>g</sub>	Total Gate Charge	V <sub>DS</sub> = 480V, I <sub>D</sub> = 2A V <sub>GS</sub> = 10V (Note 4, 5)	--	6	--	nC
Q <sub>gs</sub>	Gate-Source Charge		--	1.5	--	nC
Q <sub>gd</sub>	Gate-Drain Charge		--	2.5	--	nC
Drain-Source Diode Characteristics and Maximum Ratings						
I <sub>S</sub>	Maximum Continuous Drain-Source Diode Forward Current		--	--	4	A
I <sub>SM</sub>	Maximum Pulsed Drain-Source Diode Forward Current		--	--	12	A
V <sub>SD</sub>	Drain-Source Diode Forward Voltage	V <sub>GS</sub> = 0V, I <sub>F</sub> = 2A	--	0.9	1.5	V
t <sub>rr</sub>	Reverse Recovery Time	V <sub>GS</sub> = 0V, I <sub>F</sub> = 2A di <sub>F</sub> /dt = 100A/μs (Note 4)	--	180	--	ns
Q <sub>rr</sub>	Reverse Recovery Charge		--	1.5	--	μC

## NOTES:

1. Repetitive Rating: Pulse width limited by maximum junction temperature
2. I<sub>AS</sub>=1A, V<sub>DD</sub>=50V, Starting T<sub>J</sub>=25 °C
3. I<sub>SD</sub>≤4A, di/dt ≤ 200A/us, V<sub>DD</sub> ≤ BV<sub>DSS</sub>, Starting T<sub>J</sub> = 25 °C
4. Pulse Test: Pulse width ≤ 300us, Duty Cycle ≤ 2%
5. Essentially Independent of Operating Temperature Typical Characteristics

# Typical Performance Characteristics

Power dissipation

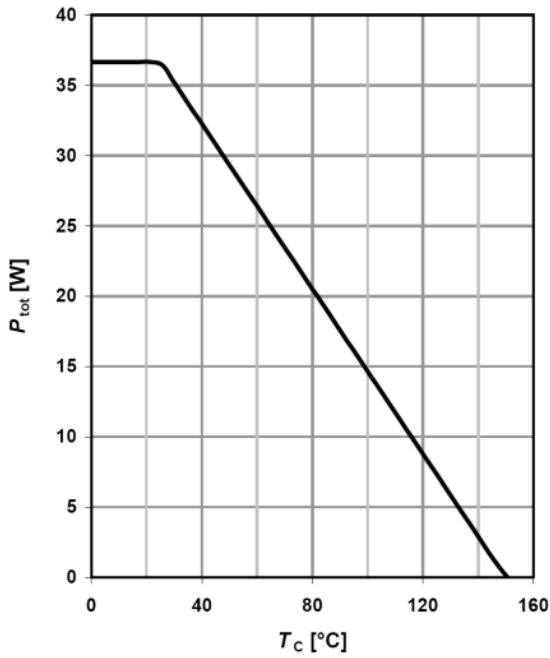

Max. transient thermal impedance

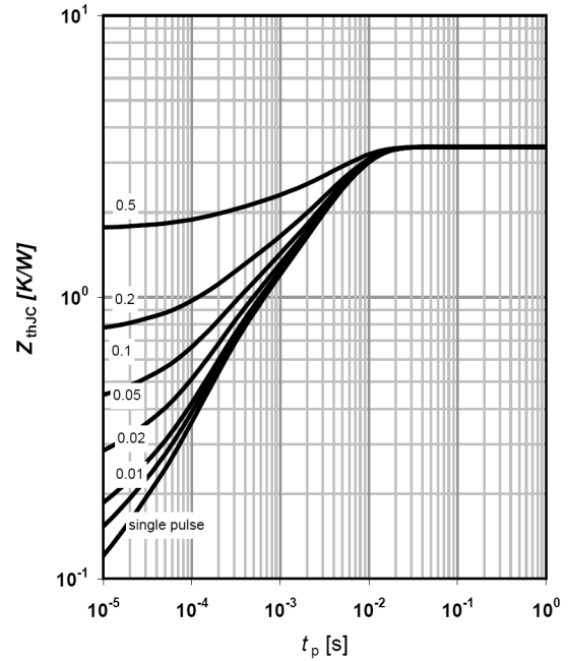

Safe operating area  $T_C=25$  °C

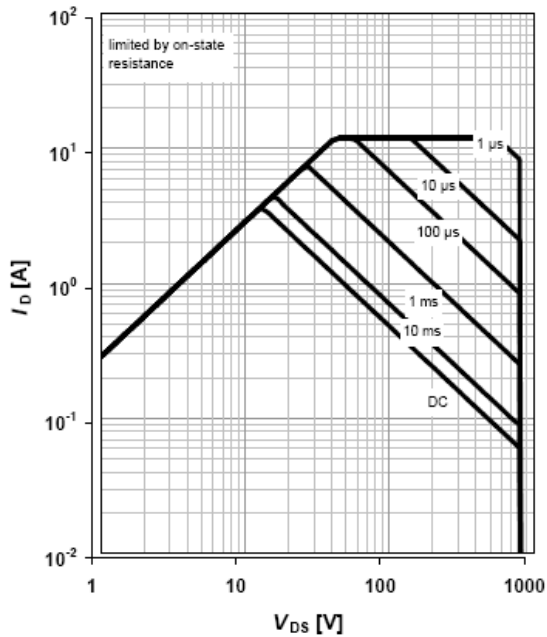

$I_D=f(V_{DS}); T_C=25$  °C;  $V_{GS} > 7V$ ;  
 $D=0$ ; parameter  $t_p$

Forward characteristics of reverse diode

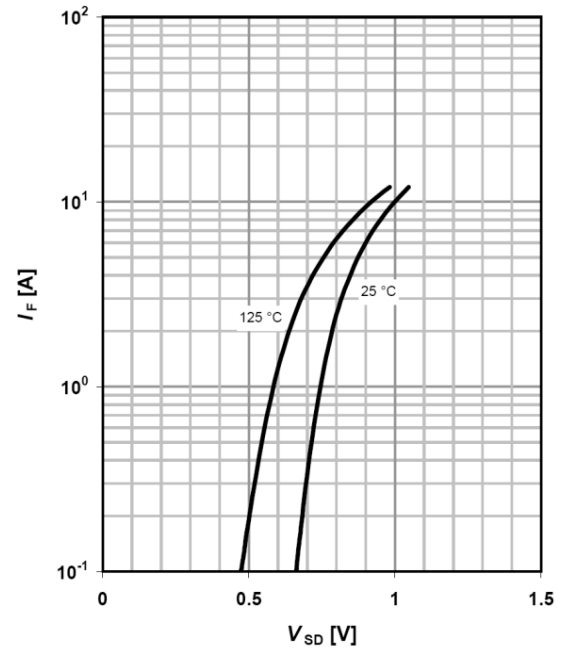

$I_F=f(V_{SD});$  parameter:  $T_j$

# Typical Performance Characteristics

Typ. output characteristic

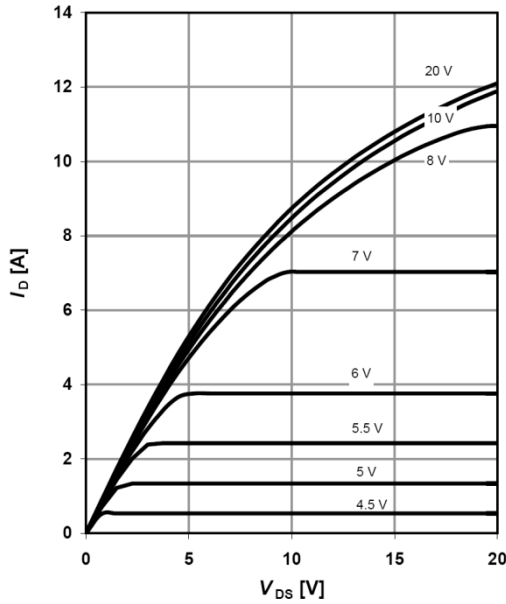

$I_D = f(V_{DS}); T_j = 25\text{ }^\circ\text{C};$   
parameter  $t_p = 10\mu\text{s}, V_{GS}$

Typ. output characteristic

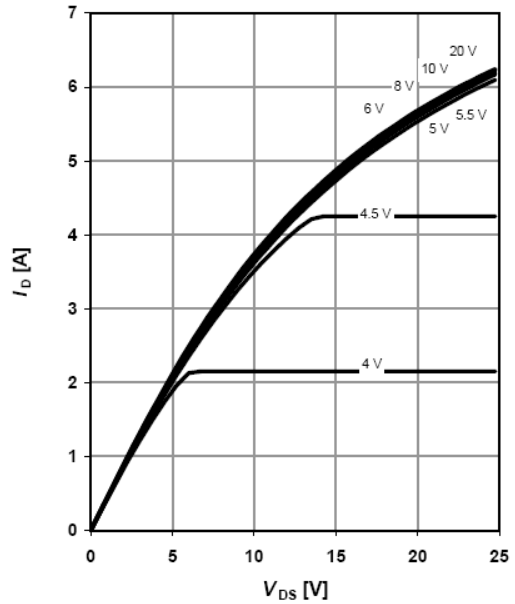

$I_D = f(V_{DS}); T_j = 150\text{ }^\circ\text{C};$   
parameter  $t_p = 10\mu\text{s}, V_{GS}$

Typ. Drain-Source on resistance

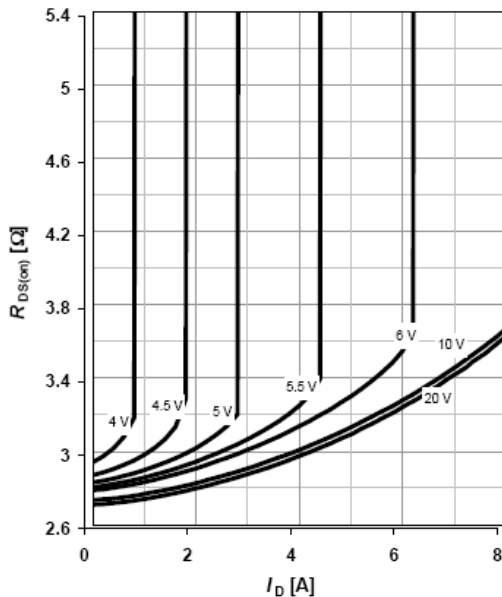

$R_{Dson} = f(I_D); T_j = 125\text{ }^\circ\text{C};$  parameter  $V_{GS}$

Typ. Drain-Source on resistance

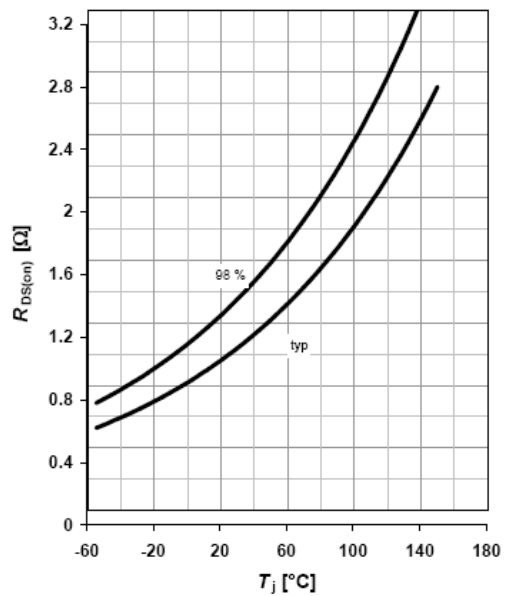

$R_{Dson} = f(T_j); T_j = 125\text{ }^\circ\text{C};$  parameter  $I_D = 2.5\text{ A}, V_{GS} = 10\text{ V}$

# Typical Performance Characteristics

Typ. Transfer characteristic

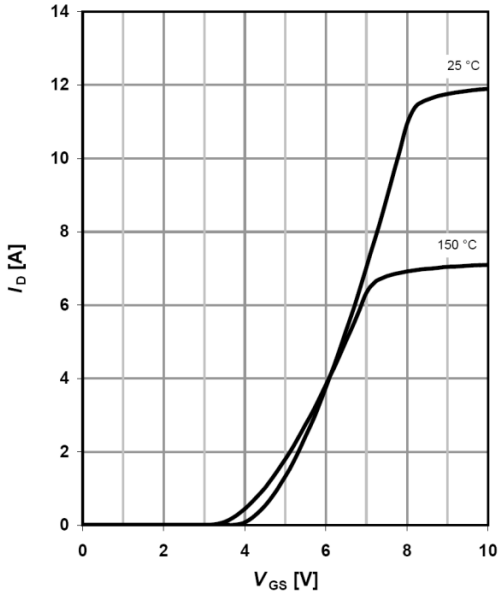

$I_D=f(V_{DS}); V_{DS}=20V$  ;  
parameter  $t_p=10\mu s$ ,

Typ. gate charge

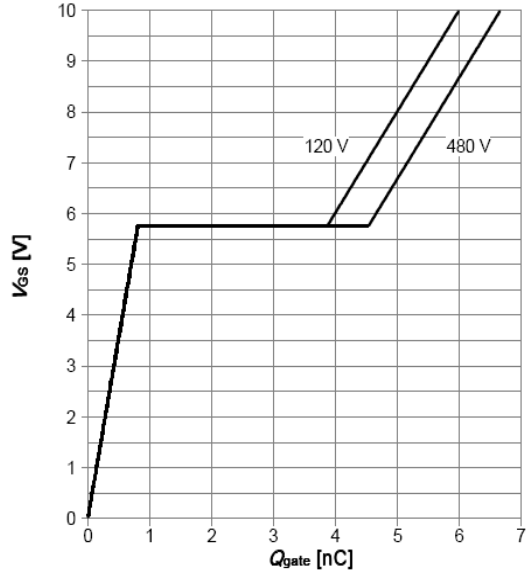

$V_{GS}=f(Q_g), I_D=2A$  pulsed

Avalanche energy

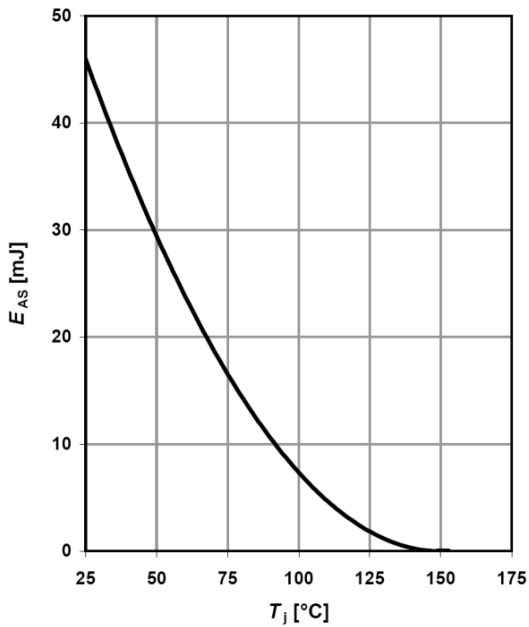

$E_{AS}=f(T_j); I_D=1 A; V_{DD}=50 V$

Drain-source breakdown voltage

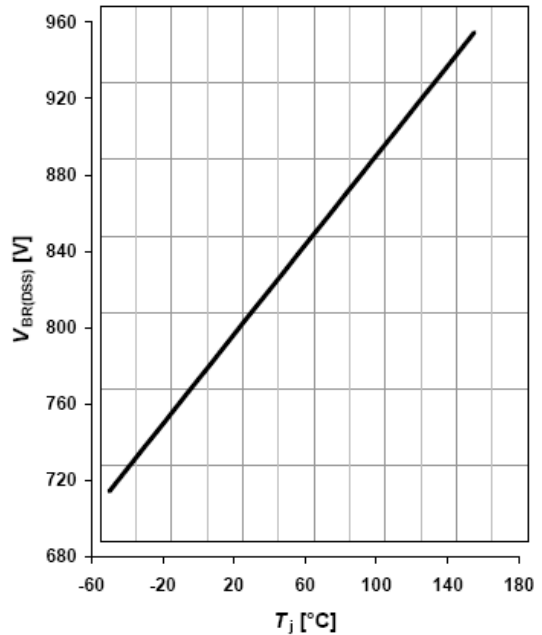

$V_{BR(DSS)}=f(T_j); I_D=0.25 mA$

# Typical Performance Characteristics

Typ. capacitances

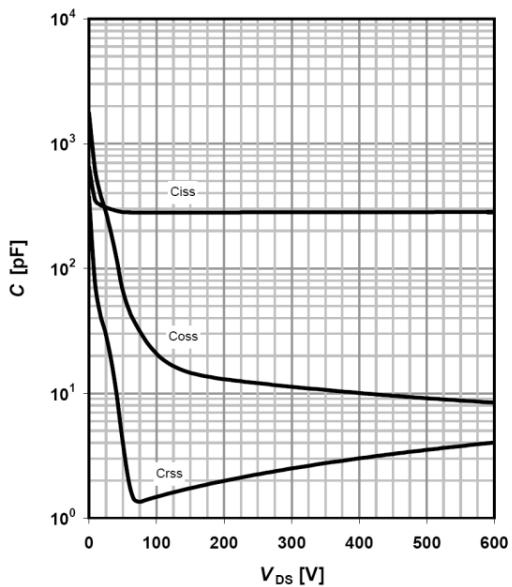

$$C=f(V_{DS}); V_{GS}=0\text{ V}; f=1\text{ MHz}$$

Typ. *Coss* stored energy

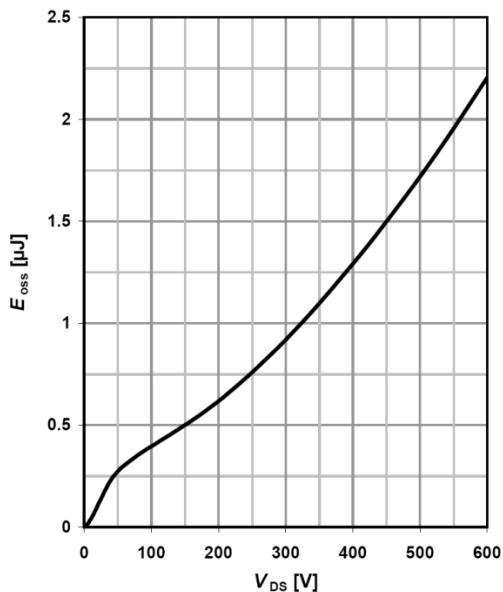

$$E_{OSS}=f(V_{DS})$$

# Test circuits

## Switching times test circuit and waveform for inductive load

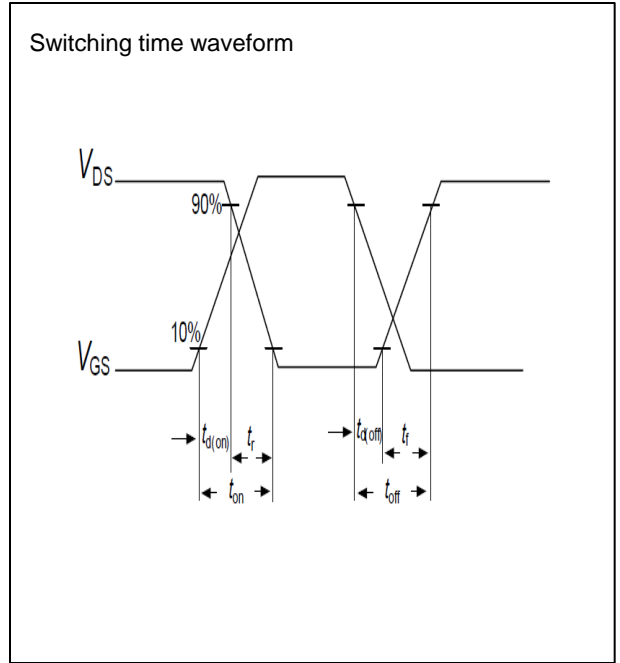
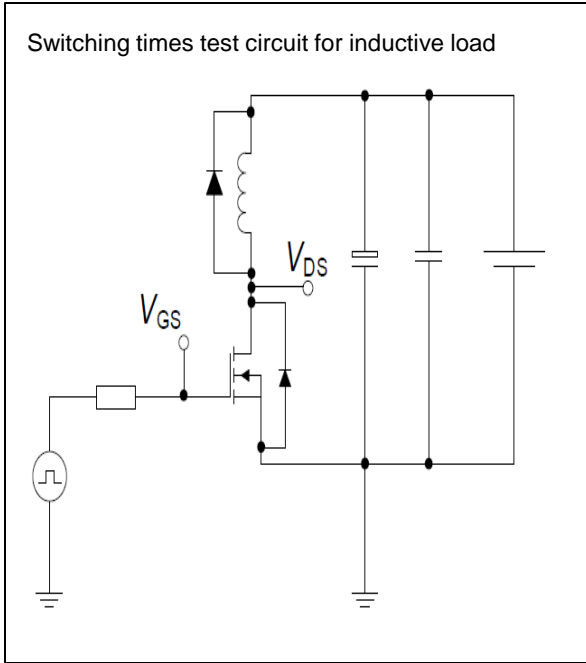

## Unclamped inductive load test circuit and waveform

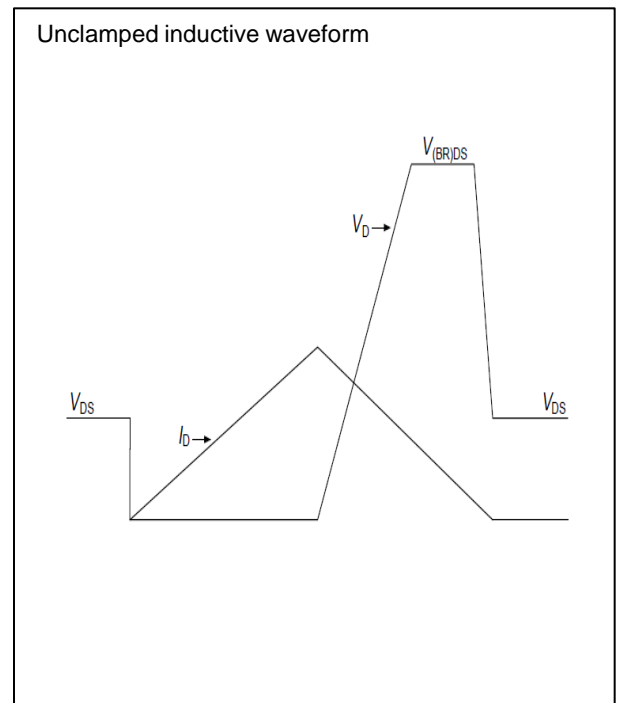
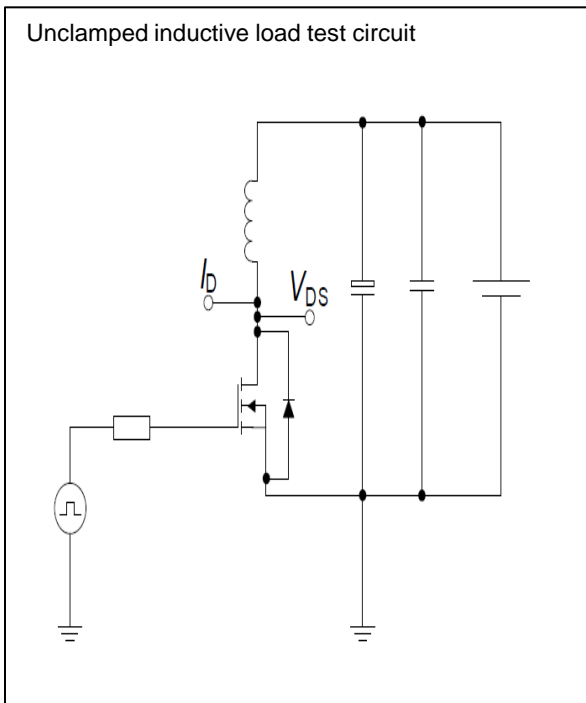

# Test circuits

## Test circuit and waveform for diode characteristics

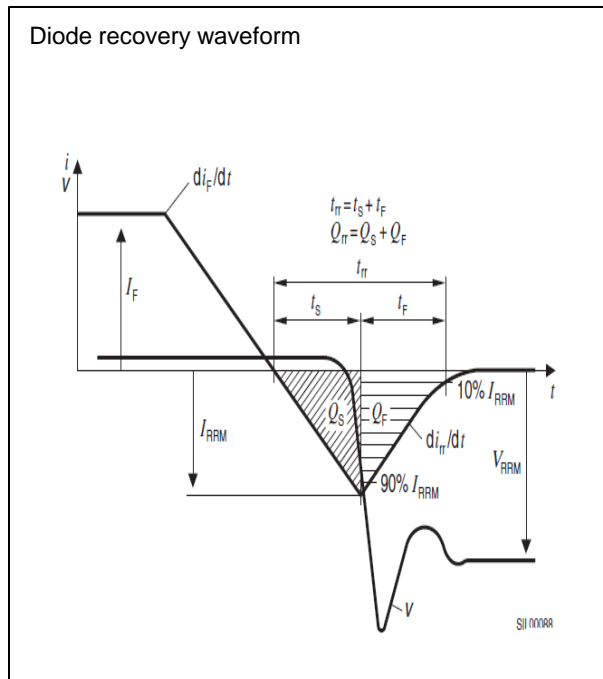
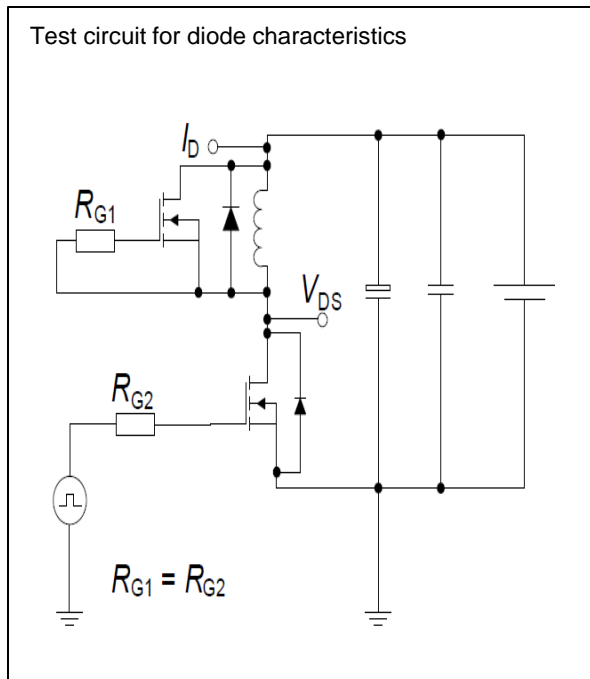



# Package Outline TO-252

TSD80R1K3S1/TSU80R1K3S1 800V 4.4A N-Channel SJ-MOSFET

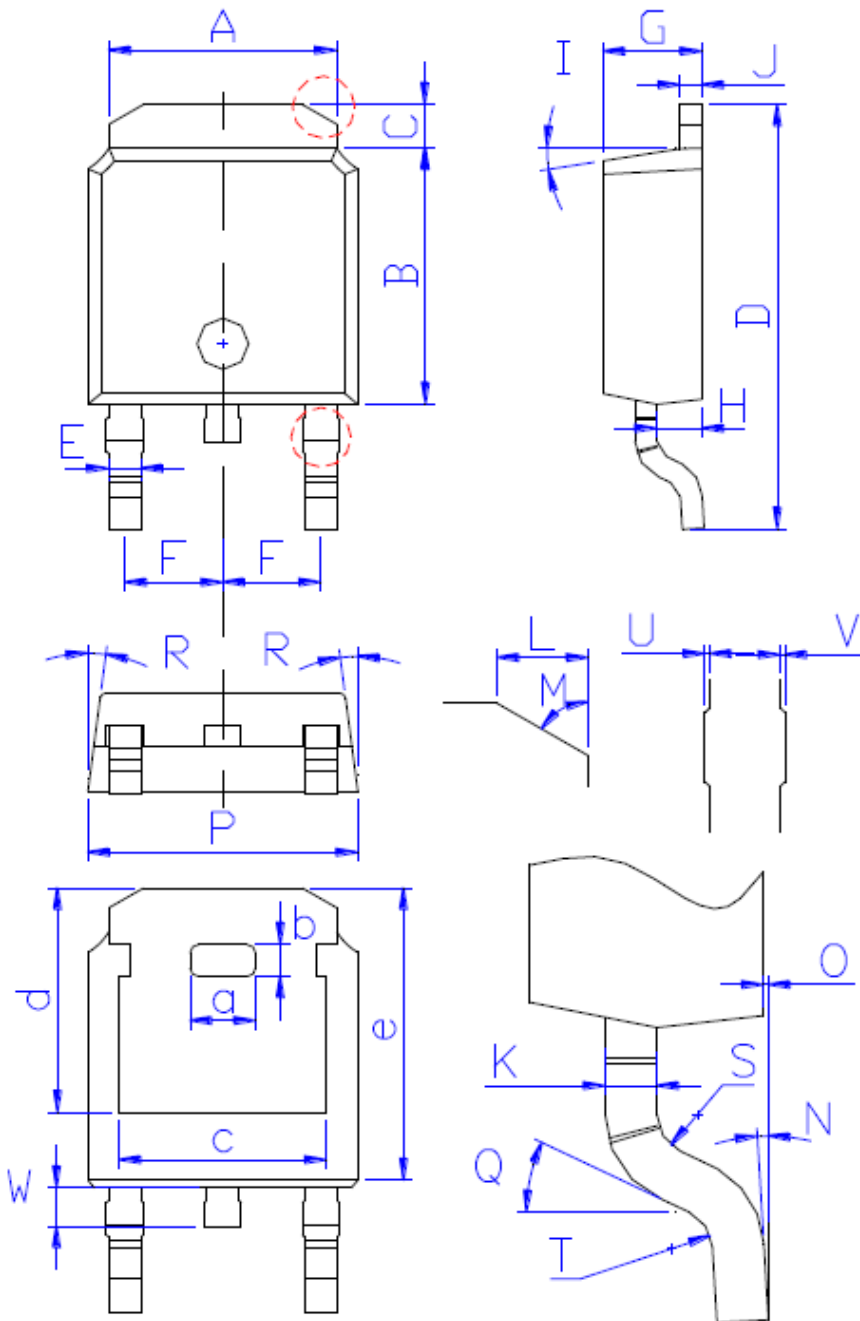

DIM	MILLIMETERS
A	$5.34 \pm 0.30$
B	$6.00 \pm 0.30$
C	$1.05 \pm 0.30$
D	$9.95 \pm 0.30$
E	$0.76 \pm 0.15$
F	$2.28 \pm 0.15$
G	$2.30 \pm 0.30$
H	$1.06 \pm 0.30$
I	$(4-10)^\circ$
J	$0.51 \pm 0.15$
K	$0.52 \pm 0.15$
L	$0.80 \pm 0.30$
M	$60^\circ$
N	$(0-10)^\circ$
O	$0.05 \pm 0.05$
P	$6.60 \pm 0.30$
Q	$25^\circ$
R	$(4-8.5)^\circ$
S	R0.40
T	R0.40
U	$0.05 \pm 0.05$
V	$0.05 \pm 0.05$
W	$0.90 \pm 0.30$
a	$1.80 \pm 0.30$
b	$0.75 \pm 0.30$
c	$4.85 \pm 0.30$
d	$5.30 \pm 0.30$
e	$6.90 \pm 0.30$

# Package Outline TO-251

TSD80R1K3S1/TSU80R1K3S1 800V 4.4A N-Channel SJ-MOSFET

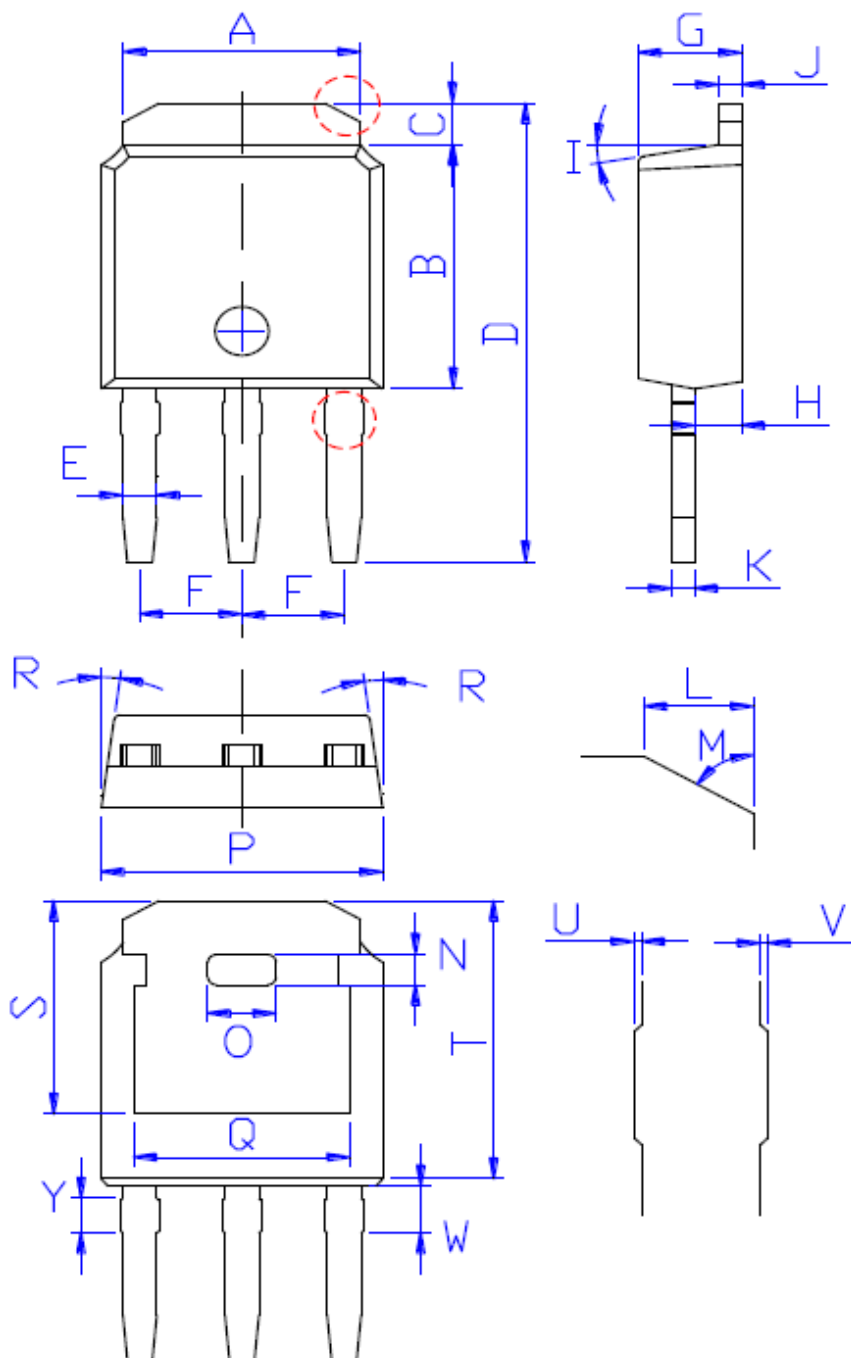

DIM	MILLIMETERS
A	5.34±0.30
B	6.00±0.30
C	1.05±0.30
D	11.31±0.30
E	0.76±0.15
F	2.28±0.15
G	2.30±0.30
H	1.06±0.30
I	(4-10)°
J	0.51±0.15
K	0.52±0.15
L	0.80±0.30
M	60°
N	0.75±0.30
O	1.80±0.30
P	6.60±0.30
Q	4.85±0.30
R	(4-8.5)°
S	5.30±0.30
T	6.90±0.30
U	0.05±0.05
V	0.05±0.05
W	1.15±0.25
Y	0.85±0.25